

Uniformly Accelerated Particle Model Worksheet 2: Accelerated Motion Representations

1. Draw a motion map along the ramp for the motion of the ball as it rolls down the ramp from rest.

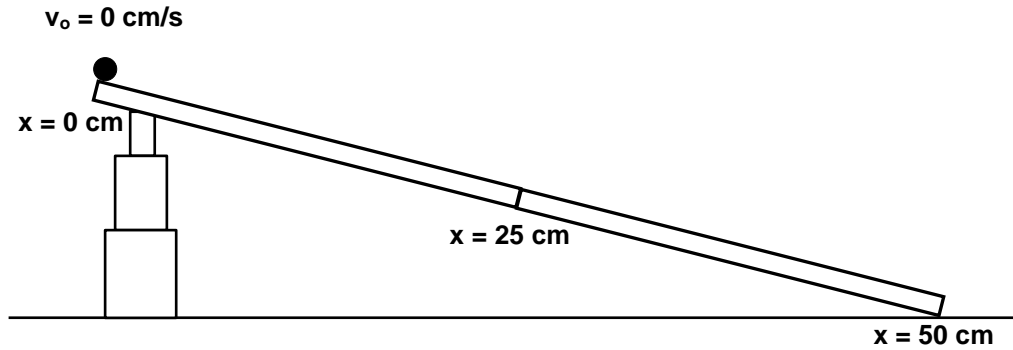

Draw graphs corresponding to the motion of the ball in **problem 1**.

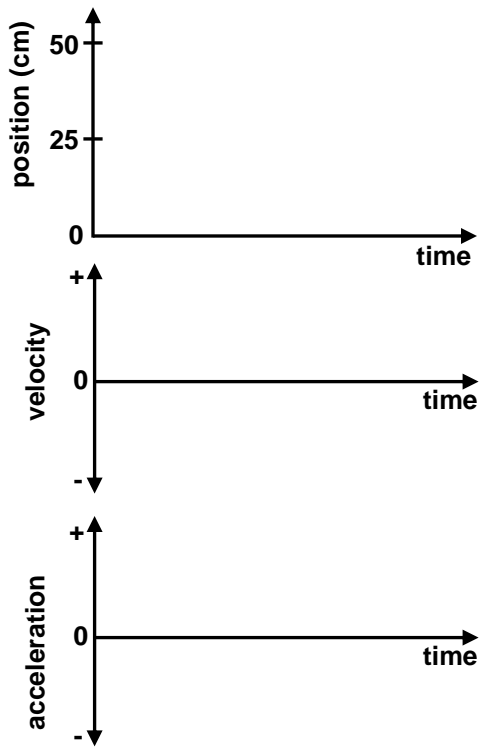

Draw graphs corresponding to the motion of the ball in **problem 2**.

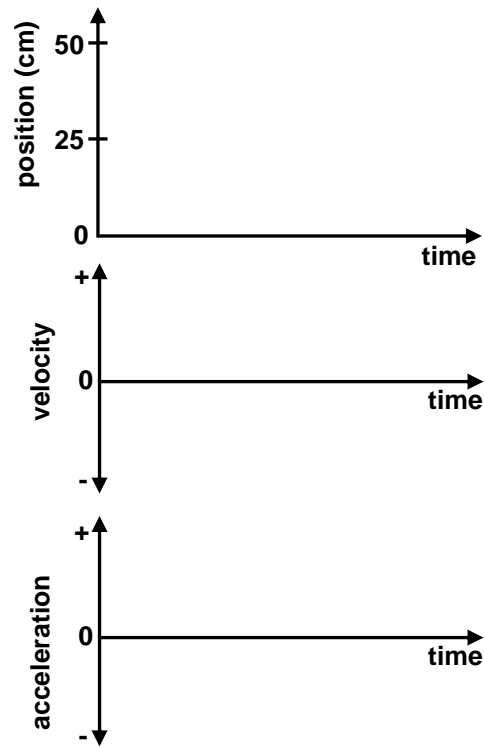

2. Draw a motion map along the ramp for the motion of the ball as it rolls up the ramp and across the level section.

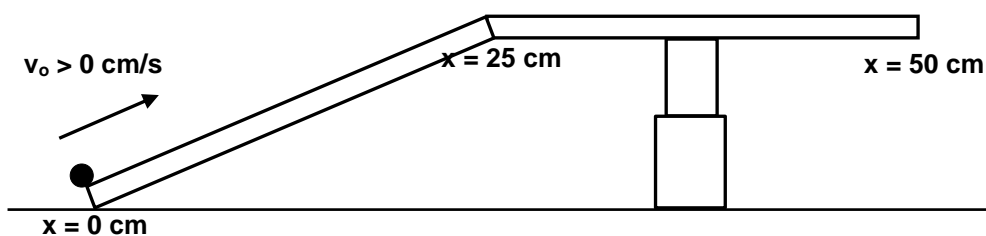

3. Draw a motion map along the ramp for the motion of the ball as it rolls down the ramps from rest.

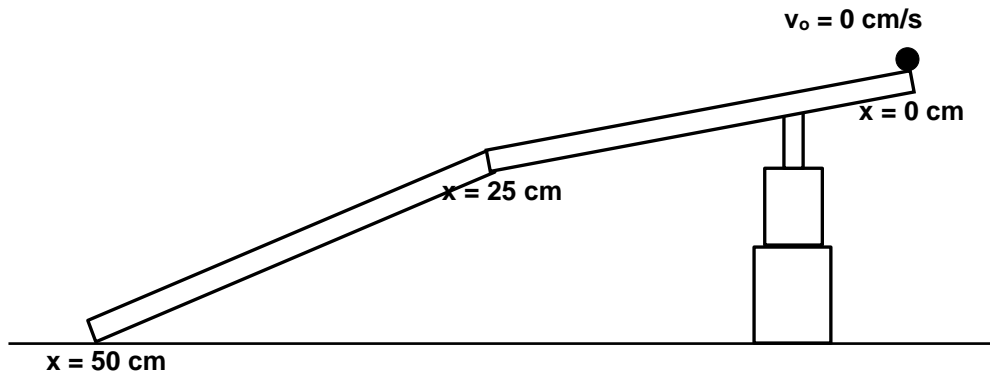

Draw graphs corresponding to the motion of the ball in **problem 3**.

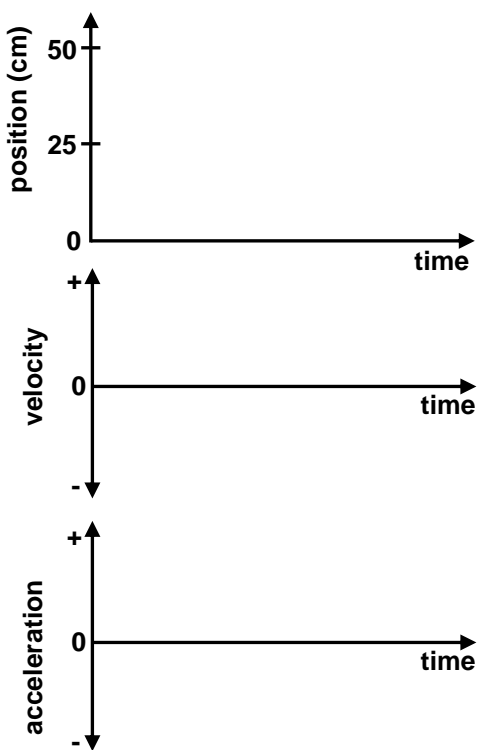

Draw graphs corresponding to the motion of the ball in **problem 4**.

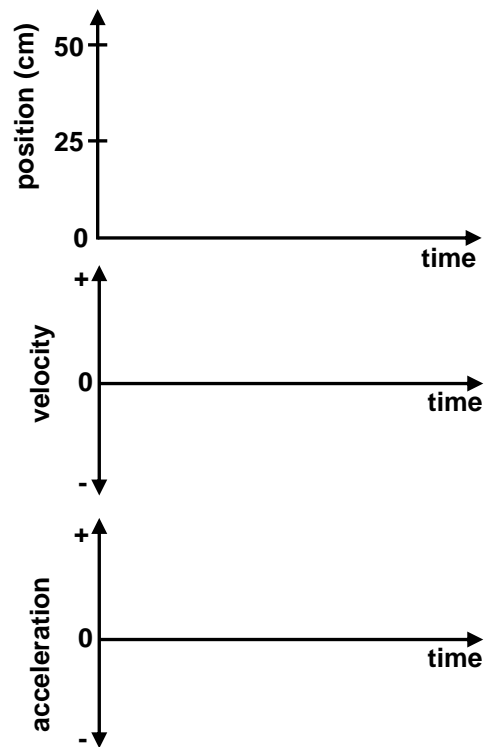

4. Draw a motion map along the ramp for the motion of the ball as it rolls up and back down the ramp.

