

# 21

## Making the Grade

### Purpose

To investigate the force and the distance involved in moving an object up an incline.

### Required Equipment/Supplies

board for inclined plane  
 spring scale  
 meterstick  
 ring stand  
 clamp  
 cart

### Discussion

One of the simplest machines that makes doing work easier is the inclined plane, or ramp. It is much easier to push a heavy load up a ramp than it is to lift it vertically to the same height. When it is lifted vertically, a greater lifting force is required but the distance moved is less. When it is pushed up a ramp, the distance moved is greater but the force required is less. This fact illustrates one of the most powerful laws of physics, the law of energy conservation.

1. A hill has three paths up its sides to a flat summit area, D, as shown in Figure A. The three path lengths AD, BD, and CD are all different, but the vertical height is the same. Not including the energy used to overcome the internal friction of a car, which path requires the most energy (gasoline) for a car driving up it? Explain your answer.

---



---



---



---



---

Fig. A

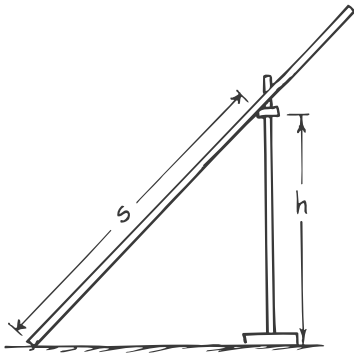

Fig. B  
Raise the cart.

## Procedure

**Step 1:** Place a clamp on a ring stand. Clamp the board in place at an angle of  $45^\circ$ , as shown in Figure B. Pull the cart up the inclined plane with a spring scale kept parallel to the plane, to measure the force. Measure the distance  $s$  from the bottom of the incline to the ring stand clamp. Record the force and distance in Data Table A.

	$10^\circ$	$30^\circ$	$45^\circ$	$60^\circ$
FORCE (N)				
DISTANCE (cm)				

Data Table A

Change the angle of the incline.

**Step 2:** Vary the angle while keeping the height  $h$  the same by sliding the board up or down inside the clamp to make angles of  $10^\circ$ ,  $30^\circ$ , and  $60^\circ$ . For each of the different angles (and distances), pull the cart parallel to the board. Record your force and distance data in Data Table A.

## Analysis

2. What pattern or relationship do you find between the forces and the distances?

---



---



---



---