

## Section 1

### WHAT IS HAPPENING IN THE WIRES?

#### INTRODUCTION

Electricity is usually invisible. Except for lightning and sparks, you never see it in daily life. However, light bulbs and a magnetic compass can show you when something electrical is happening. By observing their behavior and making a few assumptions, you can begin forming ideas about electricity. This type of thinking is called “building a model”.

#### INVESTIGATION ONE: WHAT IS NEEDED TO LIGHT A BULB?

##### 1.1 Activity: Lighting bulbs in a loop

Insert three D-cells into the battery holder (as in Figure 1.1), and insert two **ROUND** bulbs (not long bulbs) into a pair of sockets. Use three wires to connect the sockets to each other and to the two “terminals” of the battery holder:

- 1) the spring inside the case near the red spot, and
- 2) the metal post on the outside of the case near the blue spot.

The bulbs should light and be of similar brightness. The battery, bulbs and wires now form a “**closed loop**”.

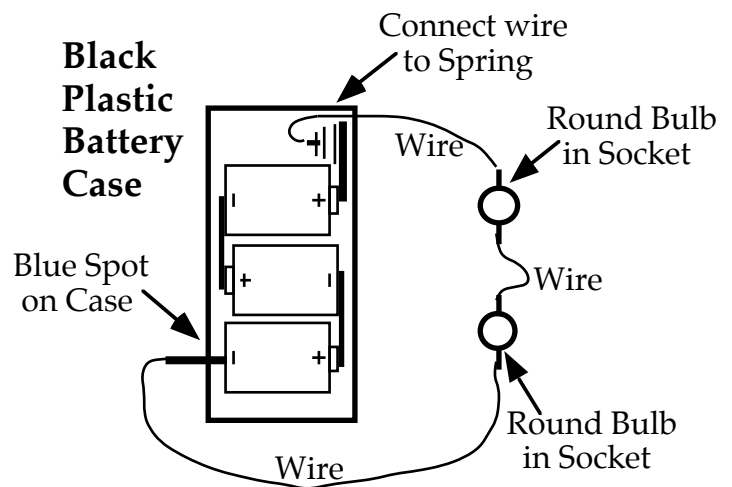

**Figure 1.1**  
**BASIC CLOSED LOOP**

1. “Break” the loop by disconnecting a wire from one end of the battery holder; then reconnect the loop. Do you see both bulbs light at exactly the same time? Do you believe that both bulbs actually light at the same time? Do both bulbs appear to go out at exactly the same time? (We will return to this question later; for now, just report your observations as well as possible.)

2. Reconnect the wire to the battery, and then disconnect a different wire somewhere else in the loop. Try doing this in several places. Be sure that you have only one break in the loop at a time. Is there any place where you can break the loop and one or both of the bulbs will still stay lit?

3. Unhook any wire and then bring it back as close as you can to where it was connected — without actually making contact. Do this slowly and carefully, watching the space between the wire and the contact point.

Do the bulbs light?

Do you think actual contact is needed for the bulbs to light continuously?

## INVESTIGATION TWO: IS ANYTHING HAPPENING IN THE WIRES?

### 1.2 Activity: Using the compass to investigate a closed loop

The magnetic compass in your kit can be used to detect electrical activity in the wires during bulb lighting. Read and follow these instructions very carefully:

1. Place the compass on the table top, as far away as possible from any metal parts. Tape the compass to the table — masking tape works best. (Place a rolled piece of masking tape below the compass.) Note that the compass is not connected to any wire. It is a detector for what is happening in the wires.
2. Stretch the loop out as far as possible; keep the battery as far from the compass as you can. (The steel case of the D-cells may have become magnetized and will interfere with the compass reading.)
3. Disconnect the loop somewhere. Place a wire, which is attached to the battery on top of the compass (Figure 1.2a), and align this wire parallel to the needle of the compass and directly over the needle.

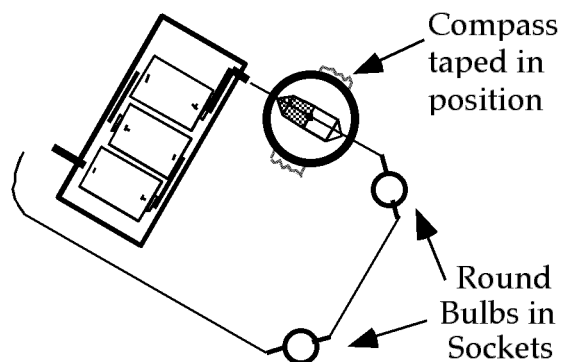

Figure 1.2a  
COMPASS TAPED IN PLACE

When you have assembled the loop in Figure 1.2a, connect and disconnect a wire several times while you observe the compass needle. It's a good idea for one person to hold the wire on top of the compass firmly while another connects and disconnects the loop.

1. Does the compass needle deflect clockwise or counter-clockwise when you connect the wire to close the loop? What happens to the compass needle when the battery is disconnected to 'break' the loop?

Close Loop:            Clockwise    Counter-clockwise (Circle one)

Break Loop:            Clockwise    Counter-clockwise (Circle one)

2. Is there any evidence that something is happening in the wire over the compass during the time the loop is broken? What is the evidence, for or against?

Do not move the compass. Break the loop and rotate the entire loop – the battery, sockets and wires together – so that the middle wire is now over the compass and parallel to the needle (Figure 1.2b). Be certain the loop is stretched out so the battery is as far as possible from the compass.

Before you connect the wire, predict what compass deflection you will observe when you close the loop.

**Prediction:**

Connect and disconnect the loop, and observe the compass needle.

3. Does the compass deflect in the same direction as it did under the first wire? Does it deflect by the same amount?

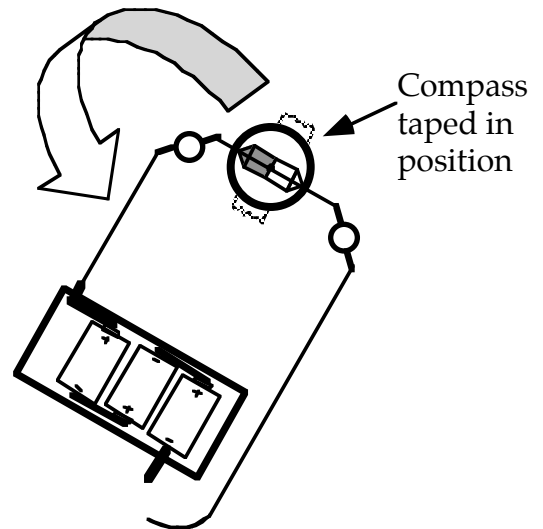

**Figure 1.2b**  
**COMPASS TAPED IN PLACE –**  
**ROTATED LOOP**

Rotate the entire loop again, so that the third wire is over the compass (Figure 1.2c). Predict what you will observe when you connect and disconnect the loop again, and observe the compass. Then try it.

**Prediction:**

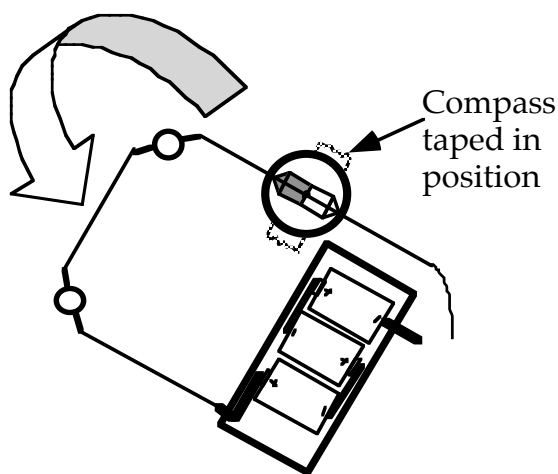

**Figure 1.2c**  
**LOOP ROTATED AGAIN**

4. What happened to the compass needle? How does this compare to its behavior under the other two wires?

5. Do you think the same thing is happening in the wires all the way around the loop? Why?

Next, reverse the orientation of the battery — by disconnecting the wires from the battery and then reconnecting them at opposite ends of the battery. Before doing so, predict what you will observe.

**Prediction:**

6. What needle deflection do you observe when you close the loop after you reverse the battery orientation? What do you observe when you break the loop?

Close Loop:            Clockwise    Counter-clockwise (Circle one)

Break Loop:            Clockwise    Counter-clockwise (Circle one)

How does this compare with your results in question #1 above?

7. Examine the compass deflections in the other two wires now that the battery has been reversed. What do you observe?

**1.3 Commentary: What is a “circuit”?**

Any unbroken loop of electrical components that forms a continuous conducting path is called a **CIRCUIT**, from a Latin word that means “to go around”.

**1.4 Exercise – Model-Building Discussion**

1. What do you think might be happening in the wires to make the compass deflection change direction when the battery orientation is reversed? Explain your reasoning.

2. Some people suggest that there is something moving in the wires. Is there any direct evidence of this? Explain.

3. If something is moving in the wires, does the direction of movement and the amount of movement appear to be the same in every wire of the circuit at one time? What is the evidence?

4. What do you think the battery does in this circuit? What is the evidence?



5. Can a compass be used to identify the direction of movement within a wire? Explain carefully.

### 1.5 Commentary: What's moving?

No one can see what moves through the wires, but something about the moving substance causes a compass needle to deflect. The property that enables the substance to do this is called **CHARGE**, from a Latin word that means "vehicle". The experiments you've done provide evidence that CHARGE is carried through wires, but they provide no evidence yet about the nature of the charges themselves.

### 1.6 Commentary: Which direction is it moving?

The reversal of compass needle deflection when the battery orientation is reversed indicates a **change** in the direction of charge flow in the circuit, but provides no information about which actual direction exists before or after the change. Scientists searched for hundreds of years trying to determine which way the charge really moved, but were unable to do so until the late 1800's. In the absence of any evidence, they decided to **assume** a direction for the motion. Such an assumption is "conventional" — that is, simply an "agreement" which isn't necessarily right or wrong but is **useful** because it is necessary for communication. The international convention is that the charges circulating around a circuit **leave the battery at the "positive" end** (red spot), travel around the circuit and **re-enter at the "negative" end** (blue spot), and pass through the battery. In later Sections we will collect evidence to determine whether this "conventional" direction is accurate or not.

### 1.7 Exercise: Which is the "conventional" direction in an actual circuit?

1. Figure 1.7 shows the circuit you constructed in Activity 1.2. Draw arrows next to each of the three wires to show the conventional direction of charge flow in these wires.

2. If the battery leads were reversed, what would happen to the direction of charge flow in the wires?

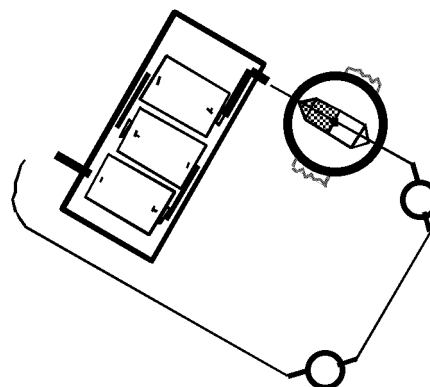

**Figure 1.7**  
**DRAW CONVENTIONAL**  
**CHARGE FLOW DIRECTION**

## INVESTIGATION THREE: TESTING CONDUCTORS AND INSULATORS

### 1.8 Activity: Identifying conductors and insulators

Use the same circuit as you constructed before (Figure 1.1), but with an additional wire (as in Figure 1.8).

This circuit (Figure 1.8) will be referred to as the "Testing Circuit". The "SOMETHING" may be anything you like — for example a key, a rubber band, or a comb.

Record your predictions and your results in Table 1.8.

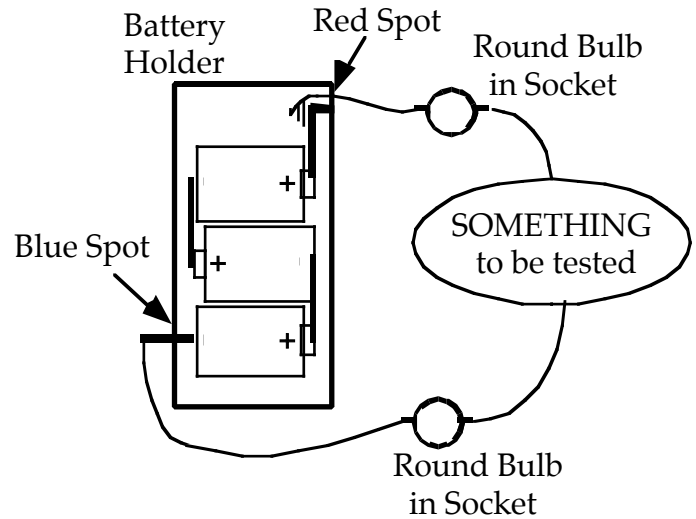

**Figure 1.8**  
**TESTING CIRCUIT FOR CONDUCTORS**

- A material in the "SOMETHING" test location that permits the bulbs to **light** is called a **CONDUCTOR**.
- A material in the "SOMETHING" test location that prevents the bulbs from lighting is called an **INSULATOR**.

**TABLE 1.8**

Test Object	Prediction (Insulator or Conductor)	Observations (Lit or Not Lit)	Classification (Insulator or Conductor)
Key			
Waxed paper			
Aluminum foil			
Shoe lace			
Pencil wood			
Pencil "lead"			
Other objects:			

1. Do most or all of the conductors have something in common? If so, what? Write a general statement.

2. Do most or all of the insulators have something in common? If so, what?

### 1.9 Activity: Bulb testing — conducting path

In order to analyze the conducting path in a light bulb, you will use a household light bulb whose glass globe has been removed; the components will be large and easy to observe and test. Obtain a 'dissected' bulb from the teacher. The filament is *very* delicate so work carefully.

1. Using the **Testing Circuit** (Figure 1.8), test each of the wire supports individually (as the 'Something' in the test circuit) to determine whether each one is a conductor or an insulator. Then carefully test the delicate filament. Record your results in Figure 1.9a.

Conductor or Insulator?

Filament -

Supports -

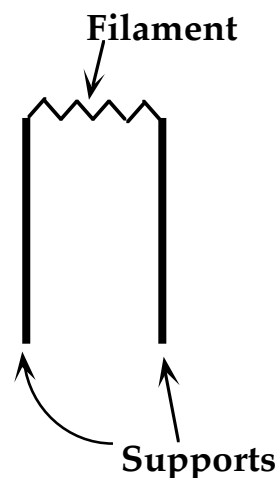

**Figure 1.9a**  
**HOUSEHOLD**  
**BULB INTERIOR PARTS**

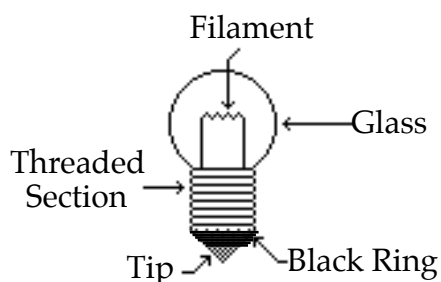

**Figure 1.9b**  
**DIAGRAM OF**  
**SMALL ROUND LIGHT BULB**

2. Study the bulb diagram in Figure 1.9b, which represents a small **ROUND** bulb from the CASTLE kit. Predict whether each of the accessible parts is a conductor or an insulator. Write your predictions in the first column on Table 1.9. Then test your predictions using the Testing Circuit (Figure 1.8). You may need to attach a thin copper wire to each alligator clip to use as a probe for small areas.

TABLE 1.9

Test Points on Small Round Bulb	Prediction (Insulator or Conductor)	Observations of Test Circuit Bulbs (Lit or Not Lit)	Classification (Insulator or Conductor)
Glass Bulb			
Threaded Section			
Black Ring			
Tip			

3. Find the combination of contact points which will cause the test bulb you are testing to light in order to determine which parts of the bulb form a continuous conducting path. In the space below, make a sketch of your test bulb showing the conducting path through the bulb.

**1.10 Activity: Socket testing — conducting parts**

Look at an empty socket and the socket diagram below; identify its five parts – a plastic base, two metal clips, and two metal plates (Figure 1.10).

1. Using your **Testing Circuit** (from Figure 1.8), test each pair of socket parts to determine whether they act as a single continuous conductor. (This time the socket parts are the “Something” to be tested.) For example: if you connect one wire to each of the two metal clips, will the bulbs light? If they do, then the two clips act as though they were a single conductor. Test every possible combination of clip, plate and base, in order to determine which parts form a continuous conductor.

Describe your results.

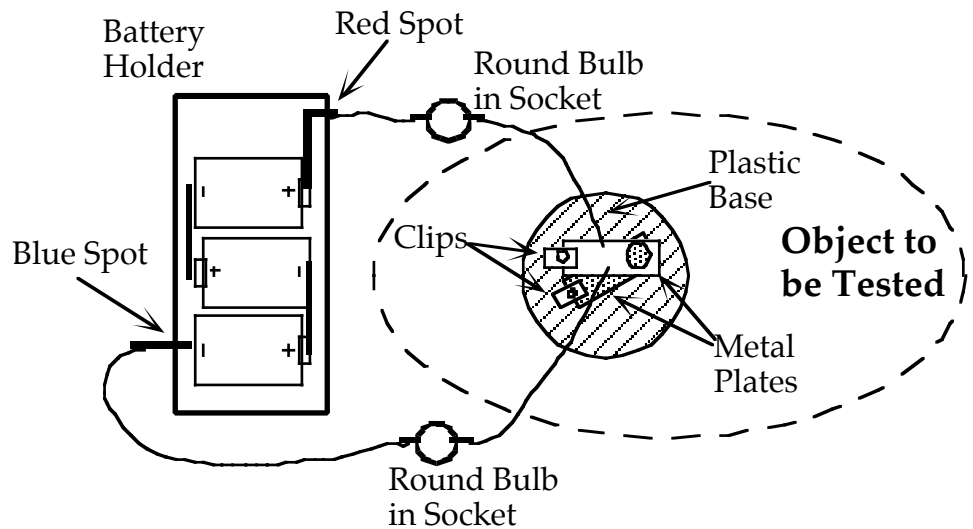

Figure 1.10  
TESTING THE BULB SOCKET



2. Considering the conducting parts of the socket, and the conducting parts of a light bulb, explain why the socket is designed the way it is.

### 1.11 Activity: Lighting a bulb with a single cell

Investigate all the ways you can use one wire and a single D-cell — and *nothing else* — to make a round bulb light. (Don't use a bulb socket or a battery holder).

1. Once the bulb lights, draw a sketch of the arrangement in the space provided. Then – **find as many different combinations of the bulb, wire and cell as you can which will cause the bulb to light**. Draw a sketch of each one in the space provided. (Hint: There are more than two.)

2. Based on your observations, what is needed to make a bulb light? In other words, describe in writing what all successful circuits above have in common.

## SUMMARY EXERCISE

Refer to the diagram at right to answer questions 1 through 3.

1. Are there any breaks or insulators in this circuit? If so, mark them on the sketch.

2. Is this circuit a continuous conducting path? Cite evidence to support your answer.

3. On the diagram, draw a colored line to indicate the path along which you think the moving charge travels. Draw arrows to indicate the direction the charge travels, based on the established convention.

4. What evidence could you provide to suggest that something happens in the wires when the bulbs are lit?

5. What is your present working hypothesis about what is happening in the wires when the bulbs are lit?

6. What happens in the wires when the battery connections are reversed? What is your evidence?

7. What is the battery doing when the bulbs are lit?

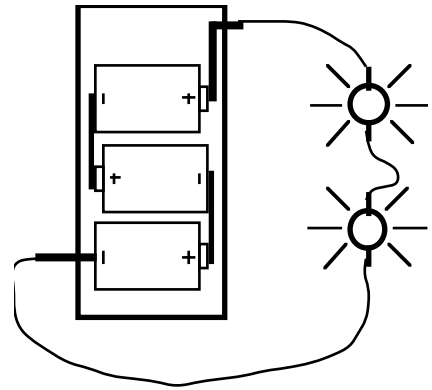

8. Based on the assumption that something flows through wires when bulbs are lit in a circuit, is the direction of the flow the same in all the wires, or does it vary in different parts of the circuit? What is the evidence for your answer?

9. What materials and conditions must be present for a bulb to light? Explain carefully.

10. On this cross-section diagram of a bulb in its socket, draw a heavy line to show a continuous conducting path that starts at a wire attached to one clip, goes through the bulb and exits through a wire at the other clip.

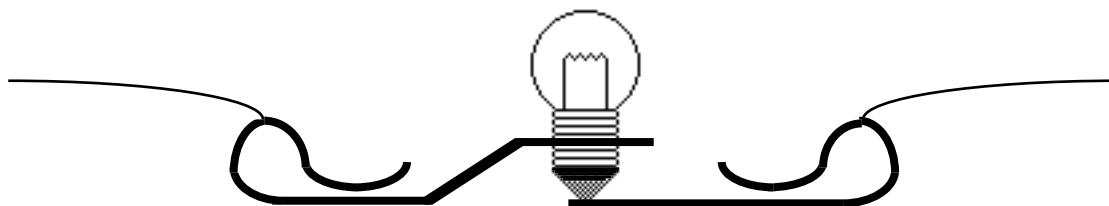

11. Based on your observations and ideas up to this point, how would you define the term 'electricity'?