

Section 2

WHAT DO THE BULBS DO TO MOVING CHARGE?

INTRODUCTION

We know the filaments of bulbs connected to batteries give off heat and light. We will now investigate how bulb filaments also control the flow rate of charge moving in a circuit. We will begin by investigating control of flow rate by non-glowing “resistors”.

INVESTIGATION ONE: HOW DO RESISTORS INFLUENCE CHARGE FLOW?

2.1 Activity: Adding a resistor

Remove one D-cell from the battery case. Set up a circuit by adding **ONLY A WIRE**.

First: Connect the wire to the spring inside the battery case.

Next: Hold the wire down directly over the compass needle.

Then: Close and open the loop a few times – **VERY BRIEFLY!** -- and note how much the needle deflects.

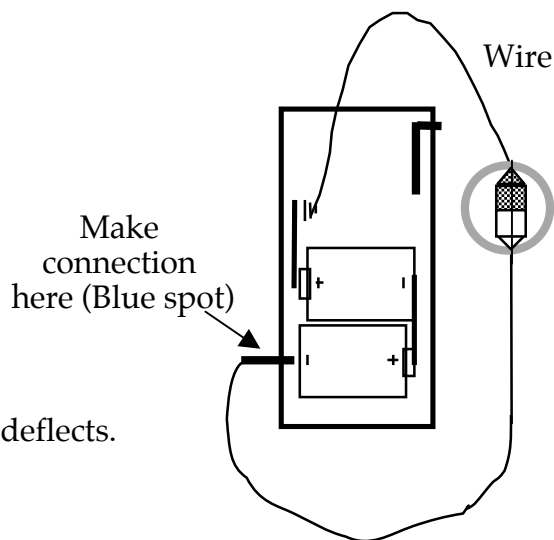

Figure 2.1a
CIRCUIT WITH WIRE
AND 2-CELL BATTERY

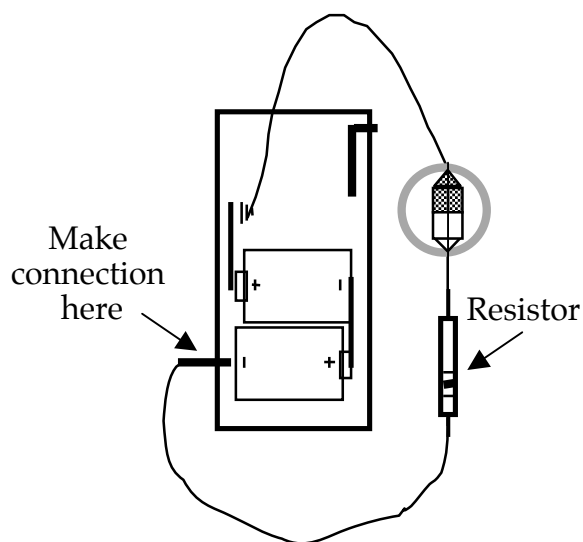
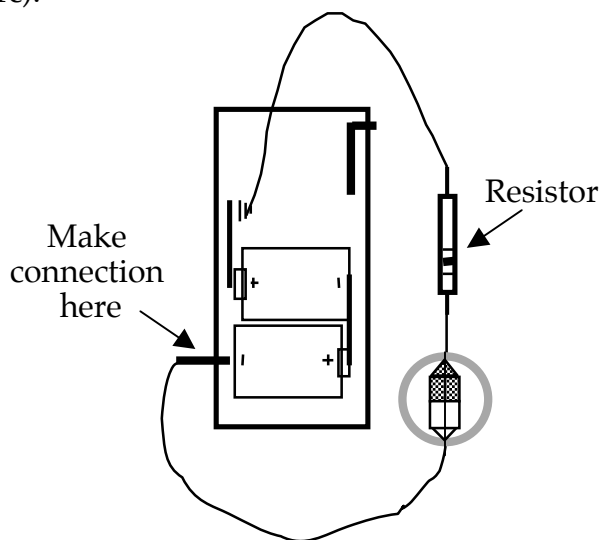

Figure 2.1b
RESISTOR ADDED IN CIRCUIT

1. Obtain a resistor from the teacher and add it in the loop. What do you observe on the compass when you close the circuit?

2. Compare compass needle deflection under the wire with charge flowing into the resistor (Figure 2.1b) with deflection under the wire with charge flowing out of the resistor (Figure 2.1c).



3. Is some charge used up while moving through the resistor? What's the evidence from the compass needle deflections?

Figure 2.1c

COMPASS 'DOWNSTREAM' FROM RESISTOR

4. What do you think the resistor does to the charge that's moving in the circuit?

5. Add another resistor in the circuit. Check the compass needle deflection under each of the three wires. Compare with the deflections you observed under the wires with one resistor.

2.2 Activity: Replacing resistors with bulbs

Redo Activity 2.1 (Figure 2.1a with no resistor). Next insert one bulb. Then add a second bulb. Then add a third bulb.

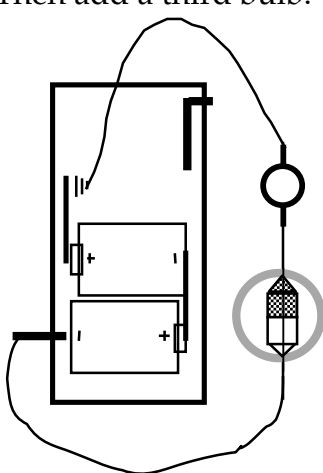

Figure 2.2a
ONE ROUND BULB

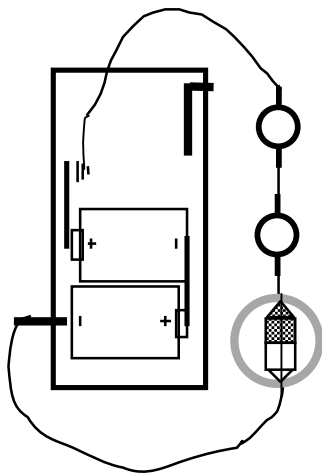

Figure 2.2b
TWO ROUND BULBS

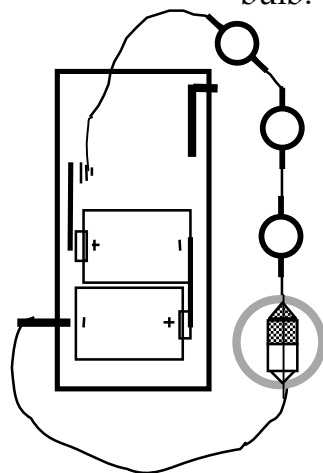
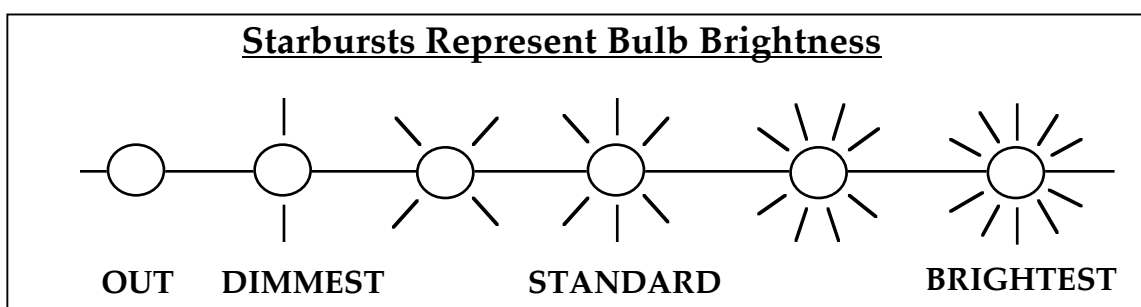

Figure 2.2c
THREE ROUND BULBS

Note the bulb brightness and compass needle deflection when there is **one** round bulb in the circuit, as in Figure 2.2a.

1. What change do you observe when a **second** round bulb is added as in Figure 2.2b?
2. What change do you observe when a **third** round bulb is added as in Figure 2.2c?
3. In what way do you think bulb filaments influence movement of charge in a circuit?

2.3 Activity: Additional symbols for circuit diagrams



1. On the circuit diagrams in Activity 2.2, draw starbursts to indicate how adding a second -- and then a third -- bulb in the circuit affects the brightness of the original bulb.

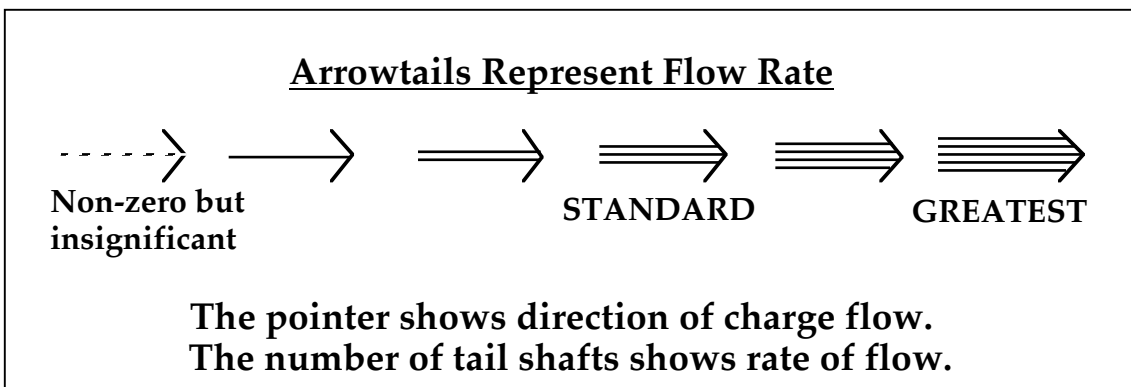

3. Place an arrowtail near each bulb in Figures 2.2a, 2.2b, and 2.2c that shows direction of movement and magnitude of the flow rate through each bulb.

2.4 Commentary: Resistance and flow rate

We have previously classified objects and types of materials as either conductors or insulators. Most of the objects we tested were

either very good at allowing charge flow -- the conductors
or very good at blocking charge flow -- the insulators

But many materials behave in a manner somewhere between these two extremes. These materials allow some flow to take place -- but at a rate that's much lower than conductors. Circuit components made of these intermediate materials are called RESISTORS.



The property of resistors that specifies the degree of ability to “hold back charge flow” is called RESISTANCE. A resistor that allows charge to go through easily has low resistance, while one that is “a harder place to get through” has high resistance.

Electrical resistance is measured in terms of a unit called the OHM — named after the German physicist and teacher Georg Ohm. The symbol for Ohm is the Greek letter *omega*, Ω . The physical design (size and shape) of these objects can have as much effect on resistance as the type of material itself. Copper is considered a good conductor; it has less resistance, for example, than glass or graphite. Besides type of material, a resistor’s size and shape affects the magnitude of its resistance. Light bulb filaments are good examples, which we will investigate later in this Section.

Most textbooks use the term CURRENT to represent flow rate of charge in a circuit.

Flow rate is measured in terms of a unit called the AMPERE — named after the French physicist André Ampere.

Flow rate is not the same idea as speed. Flow rate refers to net amount of charge per second passing through part of a circuit. Speed refers to distance traveled per second by a small bit of charge.

Consider the analogy of water flow in a river. The water normally moves with the same flow rate everywhere along a stretch of river with no tributaries to add water or drains to remove water. But at places where the river channel is narrower or shallower, individual drops of water must move faster to provide the same flow rate everywhere along the river.

A compass detects the overall flow rate of charge moving in a wire placed over the compass, not the speed of any bit of moving charge. The evidence is:

- Compass deflection goes up and down together with bulb brightness.
- Bulb lighting is caused by all the charge passing through the filament.

INVESTIGATION TWO: COMPARING RESISTANCE OF BULBS AND WIRES

2.5 Activity: Comparing the effect of different bulbs

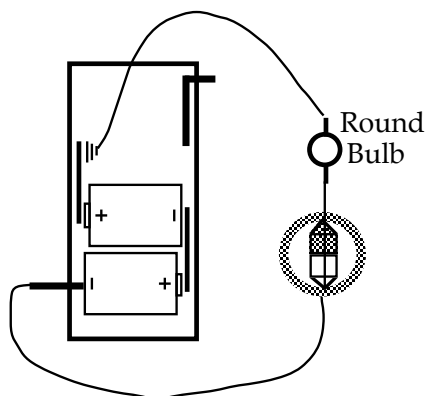

Figure 2.5a
ONE ROUND BULB

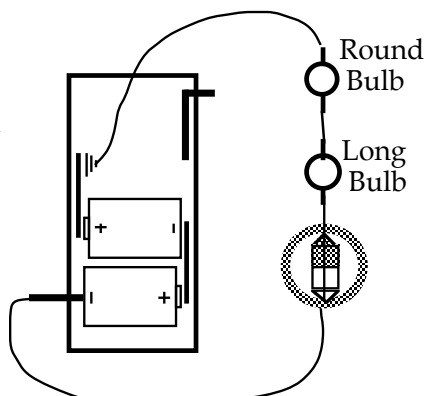

Figure 2.5b
ONE ROUND AND
ONE LONG BULB

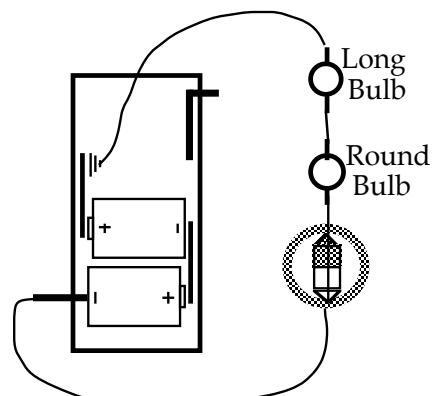

Figure 2.5c
ROUND AND LONG
BULBS REVERSED

Set up the circuits in Figures 2.5a, 2.5b and 2.5c. Note the brightness of each bulb and the compass needle deflections. Repeat with different positions of bulbs and compass.

1. Draw starbursts on the circuit diagrams to show comparative bulb brightness.
2. The round bulb appears not to be lit in Figures 2.5b and 2.5c. Is there any evidence of charge flow through the round bulb? Considering the available evidence, add arrowtails on the three circuit diagrams.
3. Compare the circuits in Figures 2.2b (from an earlier activity) and Figure 2.5b. Based on your observations, do you suspect that a long bulb has more, or less, or the same resistance as a round bulb? Explain your reasoning.

2.6 Activity: Examining filaments under magnification

Compared to the other conducting wires in a circuit, the bulb filaments are made of wire that is very thin. In this activity you will observe the thickness of round bulb filaments, long bulb filaments, support wires in bulbs, and connecting wires.

Use a dissecting microscope or other magnifier provided by your teacher to look at the thickness of the filament wires in round and long bulbs. Compare these with the thickness of support wires attached to the filaments. Compare them also with the plastic-covered connecting wires from your kits ('leads'), whose ends are known as 'alligator clips'.

1. How do the filament wires compare to the support wires and connecting wires?
2. Compare the thickness of the filament wires for the round and long bulbs.

- You have looked at round bulb filaments, long bulb filaments, support wires in bulbs, and connecting wires. List these four types of wire in order from thickest to thinnest.
- Which appears to provide the most difficult path for charge to follow? Which should be the least difficult? Explain your reasoning.

2.7 Activity: Detecting the resistance of straws to air flow

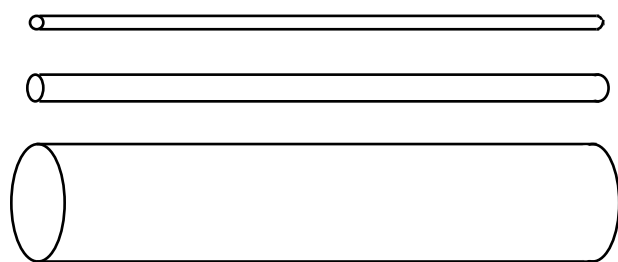

Obtain two straws of the same length but different diameters – a drinking straw and a coffee stirrer. Take a deep breath, and note the time it takes you to completely exhale through the drinking straw. Then take another deep breath and use the same effort to completely exhale through the coffee stirrer.

Figure 2.7
COFFEE STIRRER, DRINKING STRAW,
AND PAPER TOWEL TUBE – SAME LENGTH

- Compare the amounts of time it takes you to completely exhale through a drinking straw and through a coffee stirrer.
- Do you exhale more air through either straw?
- Repeat the activity with each straw, and this time direct the flow of air from the straws onto the palm of your hand. What does your hand feel?
- Next take a paper towel tube and cut it to the same length as the straws. Again, with the same effort from your lungs, exhale a full breath of air. How does the tube affect the time to exhale and the flow of air from your lungs?
- Compare the times it takes to “charge” your lungs by inhaling through the straw, the stirrer and the paper towel tube.
- Compare the effect of tube diameter on rate of air flow with the influence of bulb filament diameter on the rate of charge flow.

2.8 Activity: Comparing the resistance of wire with a bulb filament

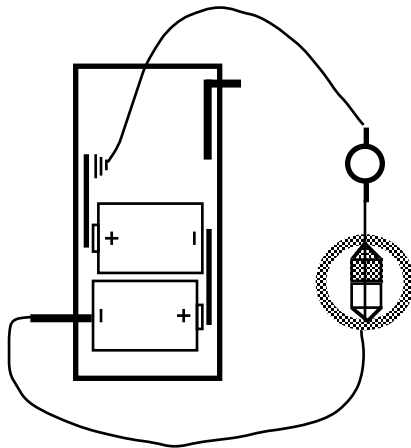

Figure 2.8a
CIRCUIT WITH ONE
ROUND BULB

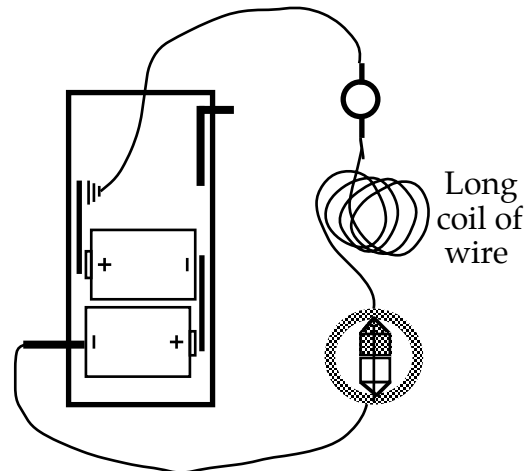

Figure 2.8b
CIRCUIT WITH ADDED
COIL OF WIRE

1. Start with a circuit containing a round bulb and two D-cells. Open the circuit and add a long coil of wire provided by the teacher. Before adding the wire, make a prediction:

Predict the effect on compass needle deflection:

Predict the effect on the round bulb brightness:

2. Connect the long coil of wire and describe the effect on needle deflection and bulb brightness. What can you conclude about the resistance of wire from this activity?



2.9 Activity: Confirming the resistance of connecting wire

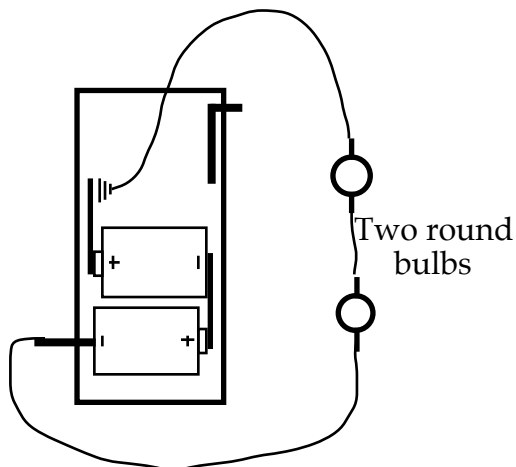
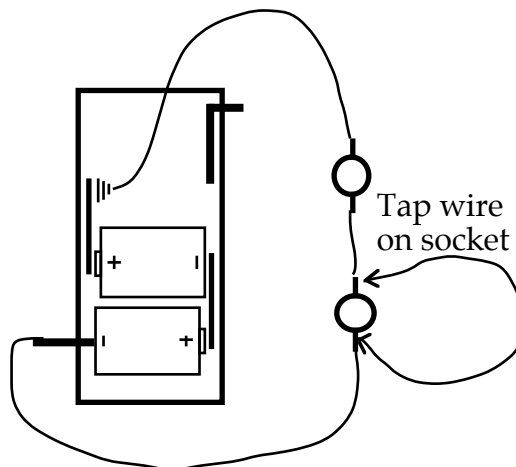

Figure 2.9a
Figure 2.9b
ADDING A WIRE 'AROUND' ONE ROUND BULB



1. Set up the circuit in Figure 2.9a. Then use an extra wire to make a new path 'around' one of the round bulbs. Before doing so, make a prediction.

Predict: What do you think you will observe? Why?

2. Connect an alligator clip to one side of the socket. Tap the other end on the other side of the socket **very briefly**, and observe what happens. Based on your observations, what do you think the extra wire is doing?



INVESTIGATION THREE: RESISTANCE OF BULB COMBINATIONS

2.10 Activity: Stirrers in series

The teacher will give you four thin plastic coffee stirrers and some masking tape. Tape two of the stirrers together end to end, to make a new straw twice as long. A good way is to place two stirrers together at one end of the tape and then roll them toward the other end of the tape. Be careful to keep the ends of the tube open and avoid gaps that might leak air. Set this pair aside.

1. Blow through **one** of the stirrers. Record the time required to exhale one full breath of air.
2. Now take the pair of stirrers and with a new breath of air, record the time required to exhale through two stirrers taped in series.
3. Finally tape all four stirrers together and measure the time needed to exhale through four stirrers in series.
4. Explain how the length of a conducting tube will influence the rate of flow through it.

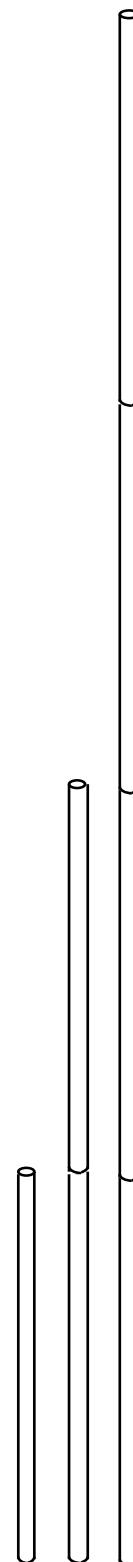

Figure 2.10
STIRRERS IN SERIES

2.11 Activity: Stirrers in parallel

Obtain four thin stirrers. Again, for reference, take a deep breath and exhale through a single thin straw. Notice the time it takes for the air in your lungs to flow through the stirrer. Then place two stirrers side by side -- "in parallel" -- and exhale through both of them together.

1. Does it seem easier or more difficult to exhale through two straws or a single straw?
2. Next place all four straws in your mouth as a small bundle and exhale a full breath. How do four stirrers in parallel compare to a single thick drinking straw?

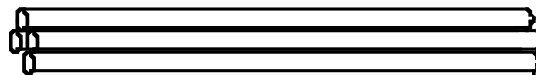

Figure 2.11
FOUR 'PARALLEL' STIRRERS

3. If you were forced to breathe through four drinking straws for a full day, how would you prefer to have them arranged – in series or in parallel? Explain your reasoning.

2.12 Activity: A circuit with parallel bulbs

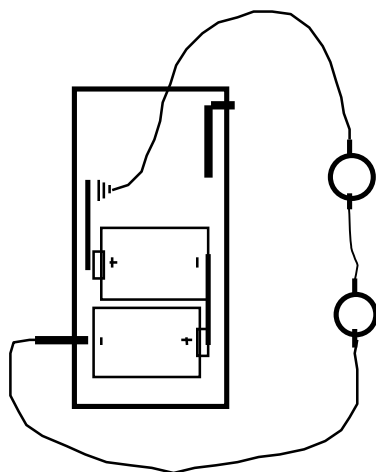

Figure 2.12a
ADDING A ROUND BULB IN PARALLEL

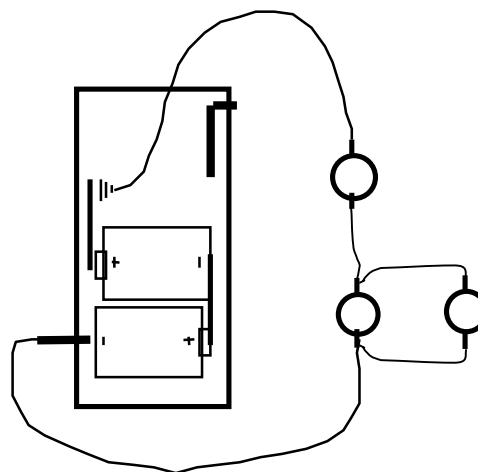

Figure 2.12b

1. Connect a circuit with 2 D-cells and two round bulbs, as in Figure 2.12a. Predict what you will observe when you add a third bulb as in Figure 2.12b.

Prediction:

2. Add the third round bulb by connecting it in parallel with one of the original pair, as in Figure 2.12c. What do you observe?

Use a compass to detect the change in flow rate through bulb A when bulb C is added in the diagram at right. What do you observe?

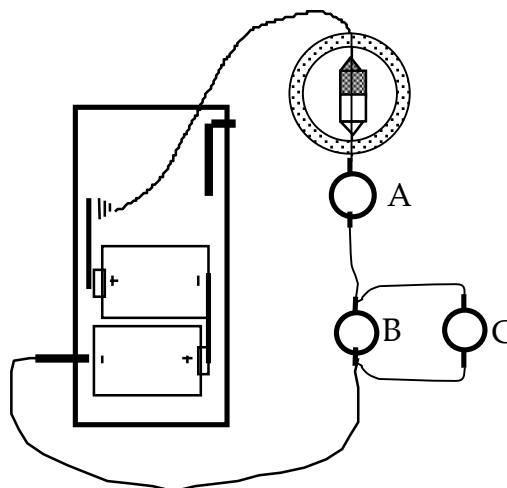

Figure 2.12c
DETECTING FLOW RATE CHANGE

2.13 Commentary: Overall resistance of series and parallel combinations

Adding more resistors in series creates the same effect as a longer single resistance. It provides greater overall resistance to charge flow through the group of resistors.

In contrast, adding more resistors **in parallel** creates the same effect as a wider or thicker single resistance. It provides less overall resistance to charge flow through the group.

Here is a useful way to think about the distinction between series and parallel:

- With **series** connections, all of the moving charge passes through every resistor. Every part of the charge is resisted every time it passes through a resistor.
- For **parallel** connections, the moving charge is split into parts. Each part will pass through only one resistor, so its motion will be resisted only once.

A summary of the last four activities indicates that multiple resistors affect charge flow in the following manner – just like for air flow:

More in series	—>	acts like single longer resistor	—>	makes flow harder
More in parallel	—>	acts like single wider resistor	—>	makes flow easier

SUMMARY EXERCISE

1. How is a light bulb like a resistor?
2. Which has the thickest filament – a high resistance bulb or a low resistance bulb?
3. What are two types of observations that can be used to indicate flow rate?
4. When more bulbs are added to a circuit, is there always more total resistance as a result? Explain.
5. What experiments suggest that wires have essentially zero resistance?